

Enclosed Series Desk
CD 30", 48", 60" & 72"

Assembly Instructions



How can we improve our assembly instructions?
Your comments and suggestions are important to us.
Please e-mail us at: support@versatables.com.

Hardware & Parts List

Enclosed Series Desk

1/4-20 Phillips Head Bolt



Qty:4

20mm Furniture Bolt



Qty:12

4mm Allen Wrench



Qty:1

1/2-13 Leveler



Qty:4

Caster & Caster with Lock



OPTIONAL

Qty:2

Main Surface



Qty:1

Zip Tie & Curly Tie



Qty:5

Kick Panel



Qty:1

Side Frame Panel (Left & Right)



Qty:2

Cross Support



Qty:1

Cable Management tray



Qty:1

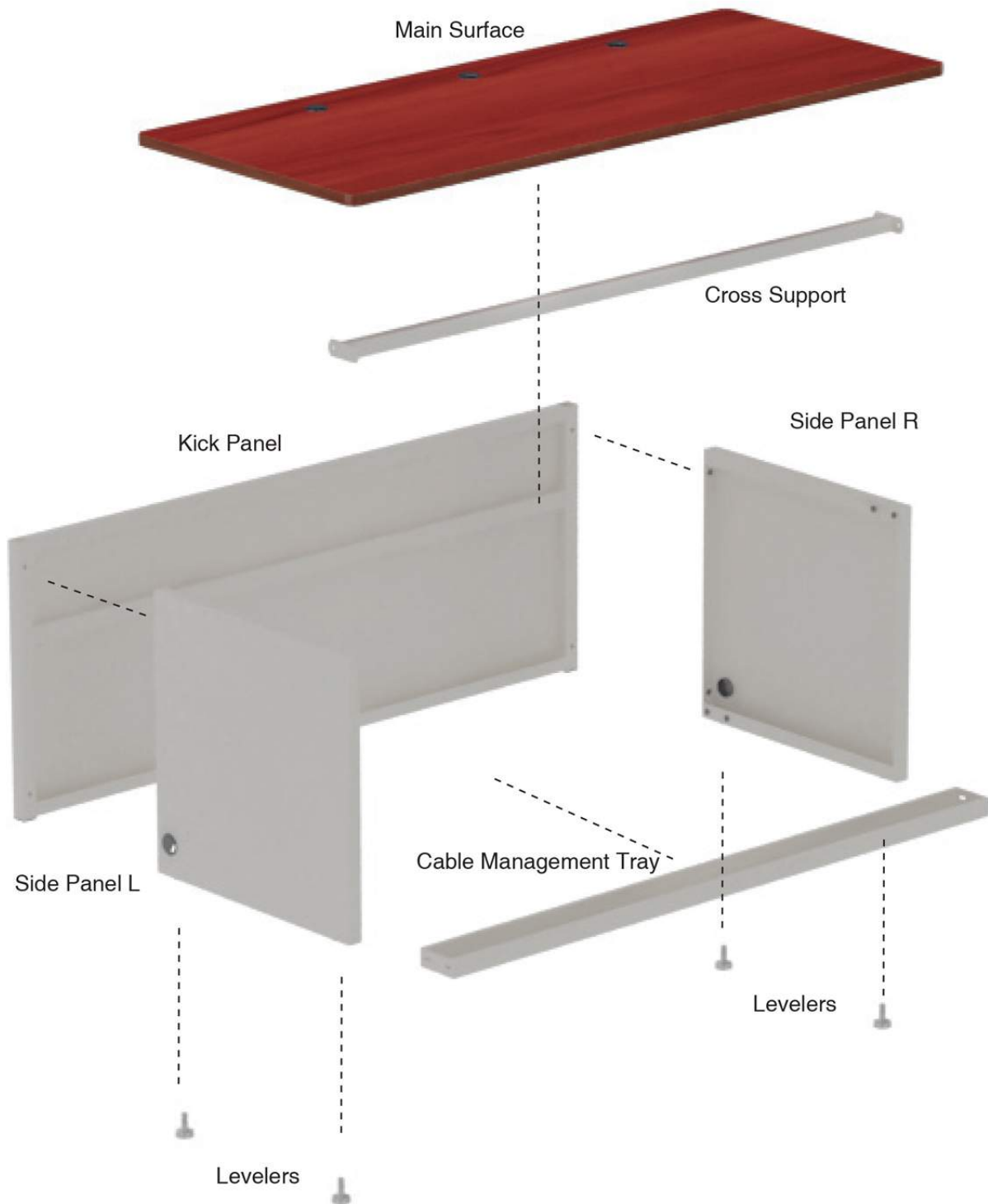

Step 1

Install Levelers

Screw in all four Levelers into Side Frame Panels.

1/2-13 Leveler



Qty:4

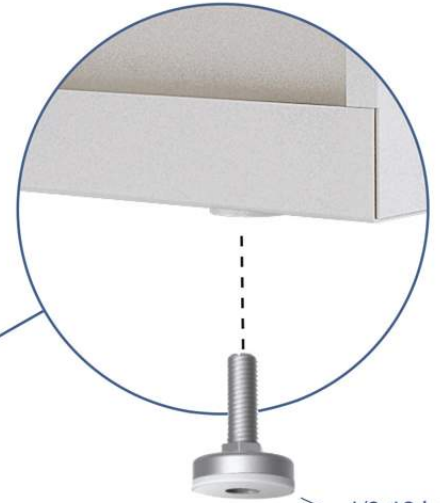

1/2-13 Leveler

Step 2

Attach Cable Management Tray

Insert (2) 20mm Furniture Bolts to each side panel half way. Then drop Cable Management Tray onto screws and tighten.

20mm Furniture Bolt



Qty:4

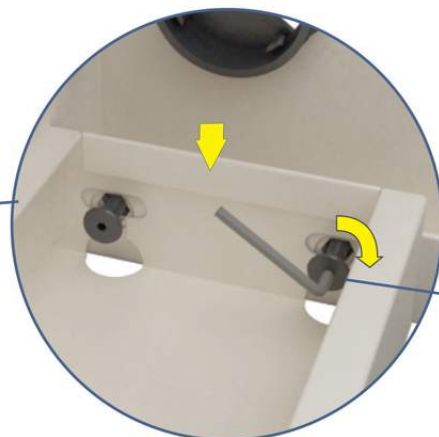

20mm Furniture Bolt

Step 3

Attach Cross Support

Place Cross Support in between Panels and use 20mm Furniture Bolts to attach them. Securely tighten 20mm Furniture Bolts after inserting all of them.

20mm Furniture Bolt



Qty:4



20mm Furniture Bolt

Step 4

Attach Kick Panel

Place Kick Panel behind both Side Frame Panels and attach it using (4) 20mm Furniture Bolts.

20mm Furniture Bolt



Qty:4

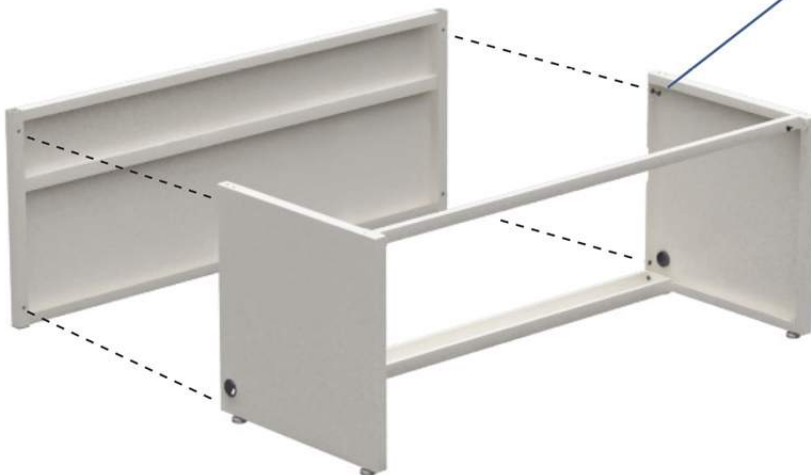

20mm Furniture Bolt

Step 5a

NOTE: This is only for the 30" deep surfaces.

Attach Main Surface

Place Main Surface on top of frame assembly and use 1/4-20 Phillips Head Bolts to attach it.

1/4- 20 Phillips
Head Bolt



Qty:4



1/4-20 Phillips
Head Bolt

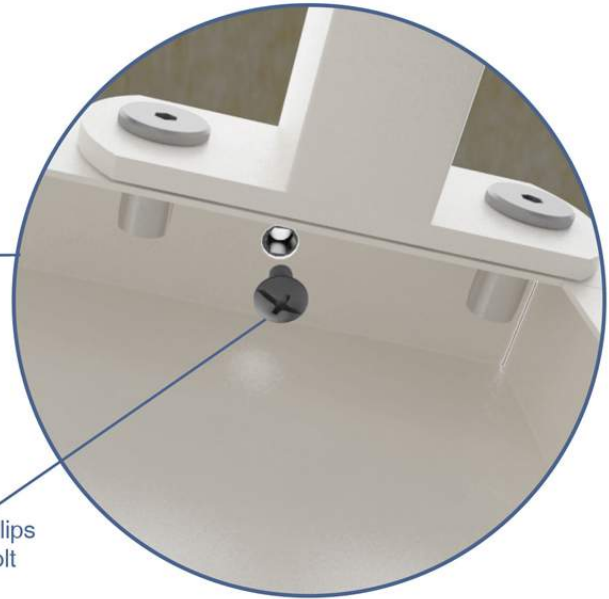

Step 5b

NOTE: This is only for the 24" deep surfaces.

Attach Main Surface

Place Main Surface on top of frame assembly and use 1/4-20 Phillips Head Bolts to attach it.

1/4- 20 Phillips
Head Bolt



Qty:4

1/4-20 Phillips
Head Bolt



1/4-20 Phillips
Head Bolt

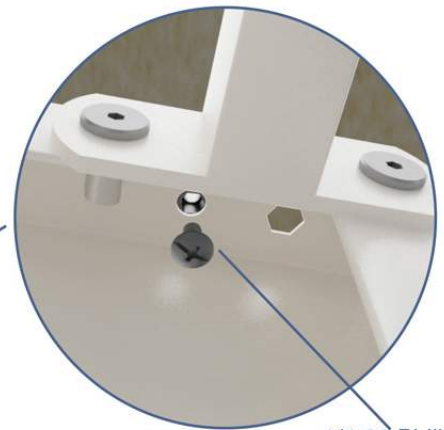

NOTE: Steps 6 and 7 are optional in case ECPU Holders are ordered.

Step 6

Optional Enclosed CPU Holder

Insert CPU Holders into Kick Panel Slots.

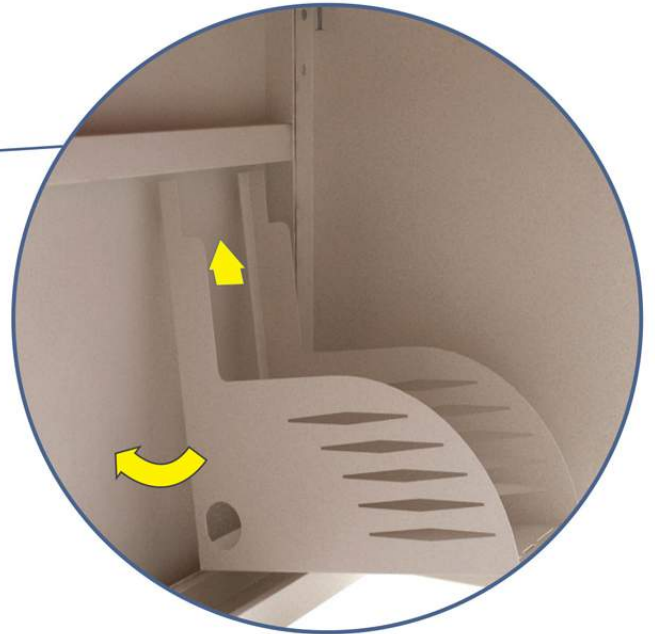

Step 7

CPU Tower Placement

Insert and place CPU Tower in holders. Use Thumb Screws to adjust fitting size of CPU Holder.

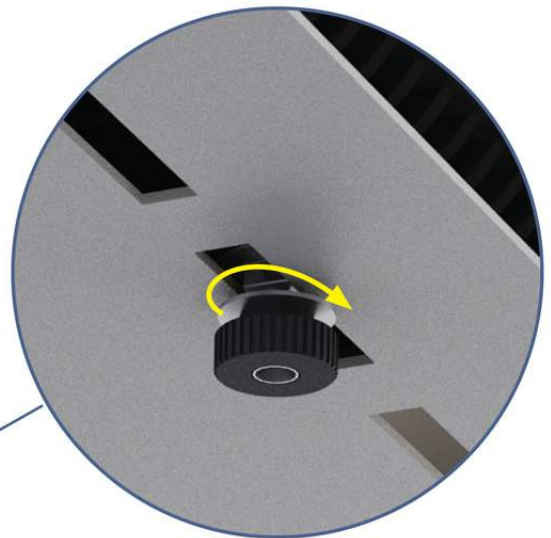
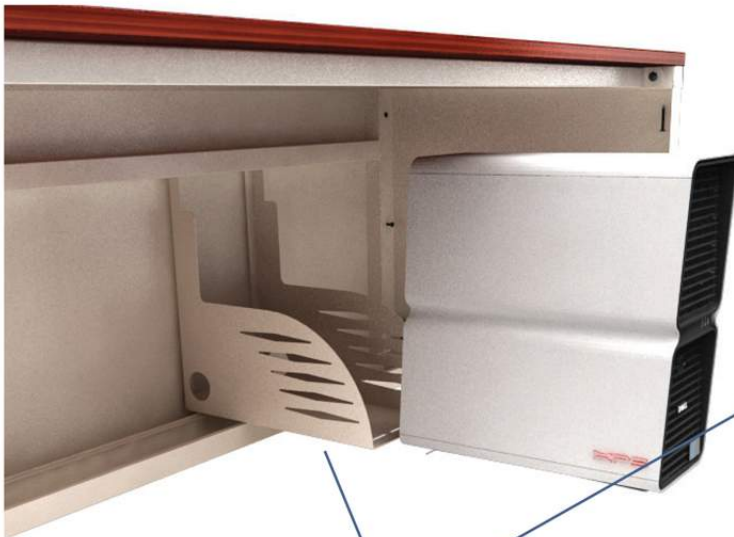

How can we improve our assembly instructions?
Your comments and suggestions are important to us.
Please e-mail us at: support@versatables.com.