

# Revolution Computer Table - RST

## KEY FEATURES

- Lifetime Warranty
- Fast Shipping
- Quantity Discounts
- High-Density Fiberboard Surface
- 14 Gauge Recycled Steel Frame
- High-Pressure WilsonArt Laminate
- Scratch / Dirt Resistant Power Coat
- Premium T-Molding
- Exceeds ADA Accessibility Guidelines
- Assembled in USA

## CERTIFICATIONS

- Buy American Act Compliant
- ANSI/BIFMA Certified
- LEED Credit Potential
- Sustainable Furnishings Council



MODEL #	WIDTH	DEPTH	HEIGHT	WEIGHT
RST-3624	36"	24"	24" to 36"	62 lbs.
RST-3630	36"	30"	24" to 36"	77 lbs.
RST-4824	48"	24"	24" to 36"	97 lbs.
RST-4830	48"	30"	24" to 36"	112 lbs.
RST-6024	60"	24"	24" to 36"	132 lbs.
RST-6030	60"	30"	24" to 36"	147 lbs.
RST-7224	72"	24"	24" to 36"	167 lbs.
RST-7230	72"	30"	24" to 36"	182 lbs.

## SURFACE COLORS



## FRAME COLORS



## INCLUDED ACCESSORIES

- (1) Enclosed CPU Holder per User
- (1) Keyboard Tray per User

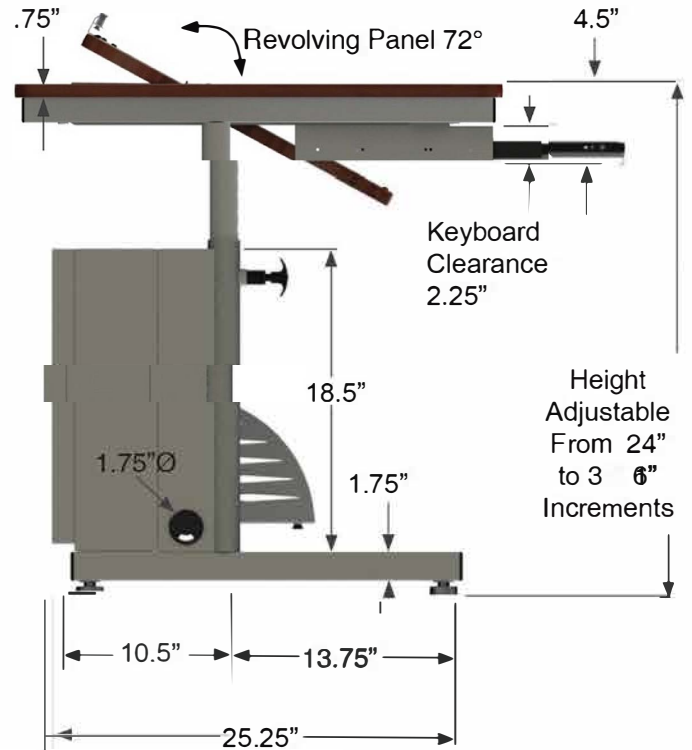

## Underside View

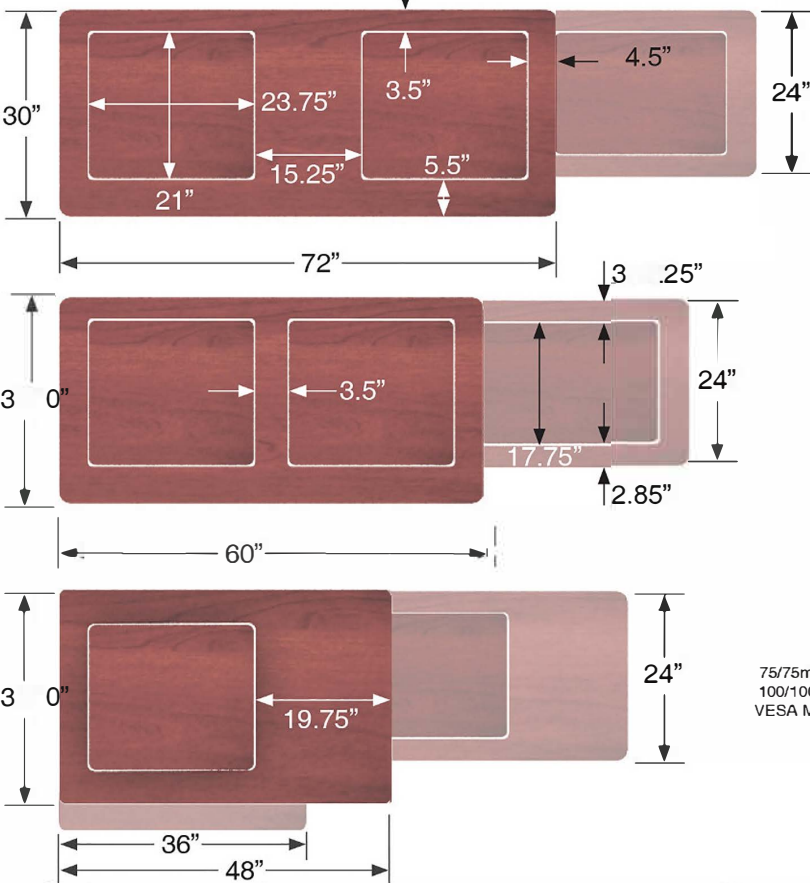
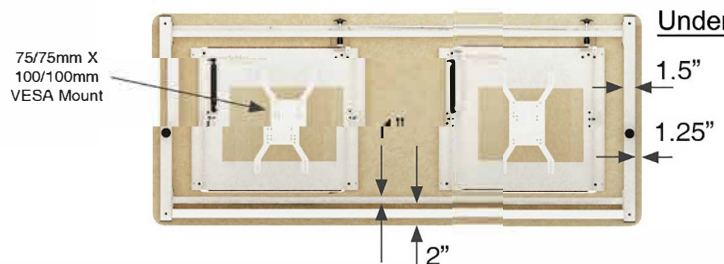

(800) 465-1660  
www.versadesk.com

14108 Towne Ave.  
Los Angeles, CA 90061

