

# Assembly Instructions

- 1** With your Desktop Riser on a desk or table, locate the cable underneath the unit's top surface. Connect that cable to the power supply included, and then plug the unit into a power outlet.



 This product is for adult use only. Children should not operate this device.

- 2** Push the button to raise the top surface of your desk riser to the maximum height. Secure the power cord with clip on base as illustrated.

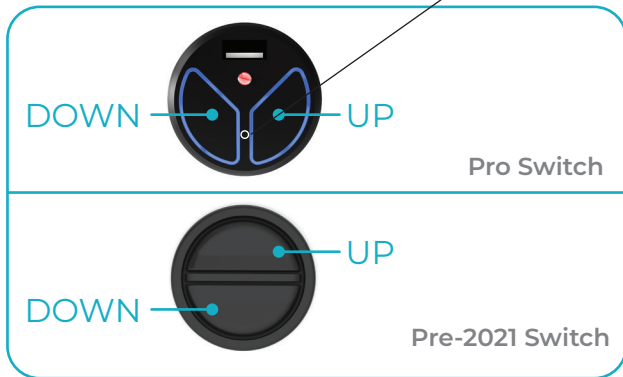

 Press once to activate child safety lock.

**NOTE:** Power cord damage caused by failure to properly secure cord away from scissor arm mechanism and is not covered under warranty.



- 3** Locate the 4 thumb screws in plastic bag (the shape of the thumb screws may be different from the diagram). Insert the 4 thumb screws half way leaving a 1/4" gap between the thumb screw and the bottom of the top surface.

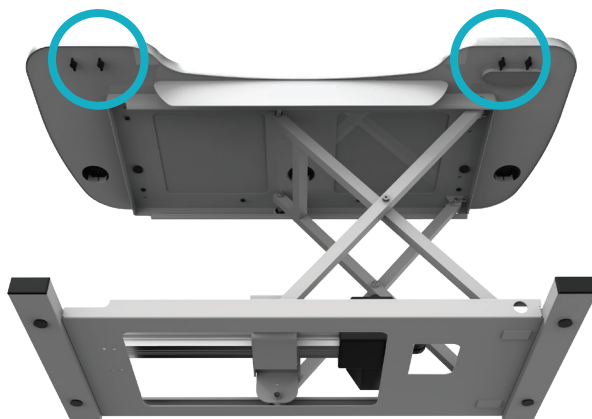

- 4** Pick up the keyboard surface. Align the slots on the side brackets to meet the loosened thumb screws on both the left and right sides. Gently slide the keyboard tray brackets into the gap between the thumb screws and the top surface.

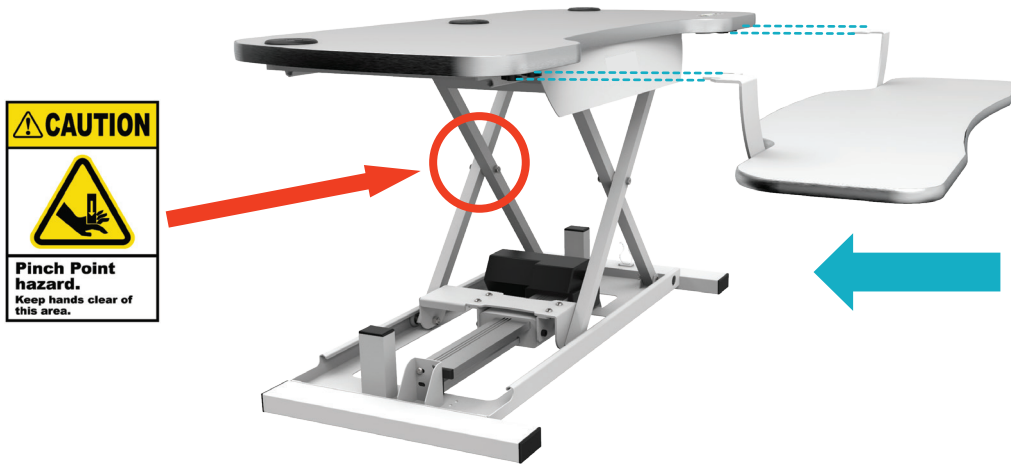

- 5** Make sure the keyboard tray is all the way in and the end of the keyboard tray is sitting under the middle bracket. Secure the side brackets to the top surface by fully tightening all 4 thumb screws.

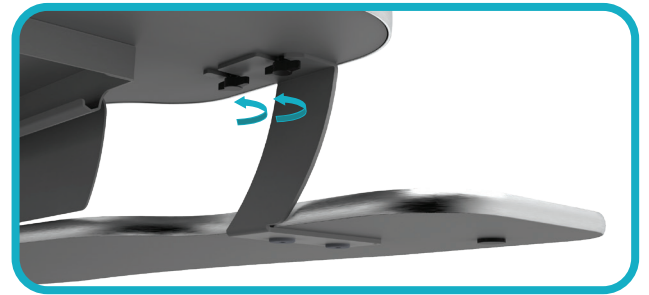

## Nice! You are all set.

Before raising/lowering your unit, make sure all cords are secured and away from all moving parts.

We hope you enjoy your new workspace and that it brings you more well-being while working.



How can we improve our assembly instructions?  
Your comments and suggestions are important to us.